



- ◆ Size 10-32
- ◆ Maximum working pressure 315 bar
- ◆ Maximum working flow 550 L/min

## Contents

Function description, sectional drawing	02
Models and specifications	03
Functional symbols	03
Technical parameters	04
Characteristic curve	05-06
Component size	07-08

## Features

- Hydraulic-operated check valve
- Connection dimensions according to DIN 24340
- Subplate mounting or threaded connection
- With or without drain port as required
- With or without pre-opening port as required
- Four opening pressures optional



## Function description, sectional drawing

The SV and SL valves are hydraulic-operated check valves with a poppet valve structure which can be opened to allow flow in the reverse direction.

This type valve is used to isolate parts of the hydraulic circuit as a safety measure to prevent load loss of pressure when the pipe bursts, or to avoid creeping movements of actuator during hydraulic lockout.

It mainly consists of the valve body (1), spool (2), compression spring (3), control piston (4) and an optional pressure relief ball valve (5).

Model SV..

The fluid can flow freely from A to B. In the opposite direction, the spool (2) is firmly held on its seat by the compression spring and system pressure. By applying pressure to control port X, the control piston (4) is pushed to the right. In this way, the spool (2) leaves the valve seat and the fluid flows from B to A.

In order to ensure the opening of the valve, a certain minimum pilot pressure is required to act on the control piston. And a certain minimum pilot pressure is necessary to ensure that the valve can open by applying pressure to the control spool (4).

Models SV...A.. and SL.A.. (with decompression function, section 1)

The valve has an additional unloading mechanism. When control pressure is provided to port X, the control piston (2) is pushed to the right. It firstly pushes open the ball spool (5.1), then the main spool (2) lifts off its seat. In this way, the fluid flows from B to A, thereby avoiding possible pressure shock.

Due to this pre-opening feature, it can achieve a stable decompression of the pressurized fluid in the cylinder.

Model SL...

The function of this valve is the same as model SV. The difference is in the addition of drain port Y. Here the annular area of the control piston (4) is isolated from port A. The pressure from port A only acts on the area A4(9) of the control piston (4).

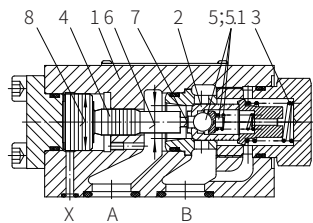

Model SV...PA..-4XJ  
(No oil drain port, with unloading function)

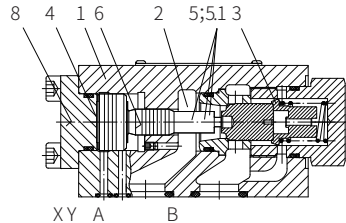

Model SL...PB..-4XJ  
(With drain port, no unloading function)

6 Area A1  
7 Area A2  
8 Area A3  
9 Area A4

## Models and specifications

connection type	model SV	model SL		
	G	P	G	P
size 10	=10	=10	=10	=10
size 16	=15	—	=15	—
size 20	=20	=20	=20	=20
size 25	=25	—	=25	—
size 32	=30	=30	=30	=30

without drain port =V  
external pilot oil drain =L

subplate mounting =P  
threaded connection =G

with decompression function =A  
without decompression function =B

4X= 40 to 49 series  
(40 to 49 series installation and connection size unchanged)

1= cracking pressure  
2= see characteristic curve  
3= A to B  
4=

sealing material  
No code= NBR seals  
V= FKM seals  
(consult for other seals)

more information in text

## Functional symbols

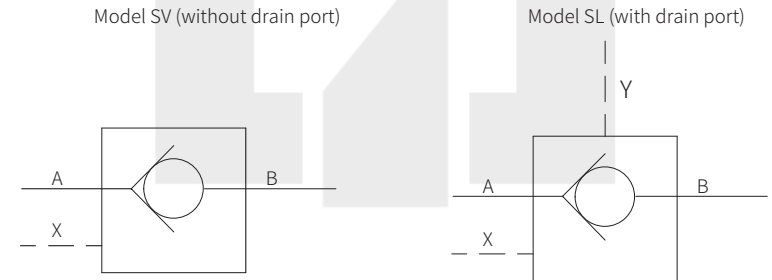

Overview						
Size		size 10	size 16	size 20	size 25	size 32
Weight	-subplate mounting	kg	1.8		4.7	7.8
	-threaded connection	kg	2.1	5.4	5.4	10
Installation position	Optional					
Environment temperature range	°C	-30 to +80 (NBR seal) -20 to +80 (FKM seal)				
Hydraulic						
Maximum working pressure	bar	315				
Maximum flow	L/min	see characteristic curve				
Control pressure	bar	5 to 315				
Fluid	Mineral oil (HL, HLP) <sup>1)</sup> in accordance with DIN 51524; Fast living organisms degraded oil according to VDMA 24568; HETG (Rapeseed oil) <sup>2)</sup> ; HEPG (Polyethyleneglycol) <sup>2)</sup> ; HEES (Synthetic Fats) <sup>2)</sup>					
Fluid temperature range	°C	-30 to +80 (NBR seal) -20 to +80 (FKM seal)				
Viscosity range	mm <sup>2</sup> /s	2.8 to 500				
Cleanliness of oil	The maximum allowable pollution level of oil is ISO4406 class 20/18/15					
Flow direction	Flow freely from A to B, from B to A when opened					
Control volume	-oil port x	cm <sup>3</sup>	2.5	10.8	10.8	19.27
	-oil port Y (model SL)	cm <sup>3</sup>	2.0	9.6	9.6	17.5
Control area	-area A1	cm <sup>2</sup>	1.33	3.46	3.46	5.72
	-area A2	cm <sup>2</sup>	0.33	0.7	0.7	1.33
	-area A3	cm <sup>2</sup>	3.8	10.17	10.17	16.61
	-area A4	cm <sup>2</sup>	0.79	1.13	1.13	1.54

Subplate mounting (Measured when using HLP46,  $\vartheta_{oil}=40^{\circ}\text{C} \pm 5^{\circ}\text{C}$ )

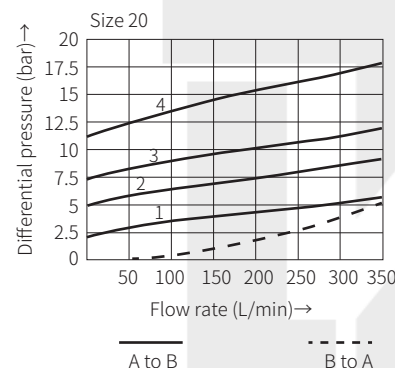
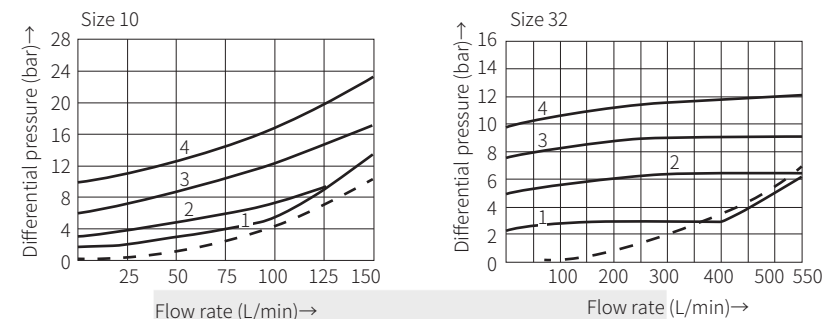

Cracking pressure (bar)

	Size 10	Size 20	Size 32
1	1.5	2.5	2.5
2	3	5	5
3	6	7.5	8
4	10	10	10

Threaded connection (Measured when using HLP46,  $\vartheta_{oil}=40^{\circ}\text{C} \pm 5^{\circ}\text{C}$ )

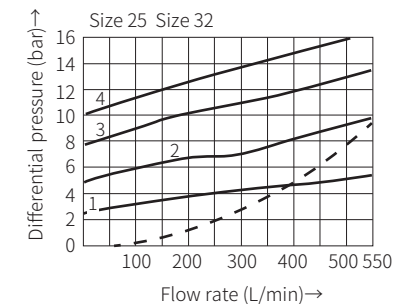
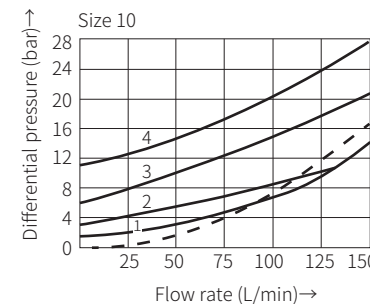

- 1) For NBR seal and FKM seal.
- 2) Only for FKM seal.
- 3) The oil must meet the cleanliness degree requested by the components in the hydraulic system. Effective oil filtration can prevent failure and increase the service life of the components.

## Characteristic curve

Threaded connection (Measured when using HLP46,  $\vartheta_{oil}=40^{\circ}\text{C} \pm 5^{\circ}\text{C}$ )

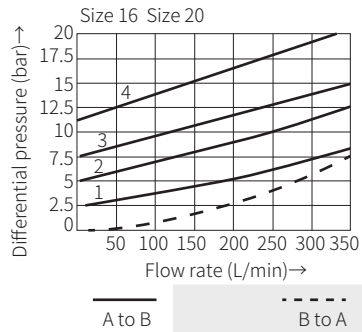

Cracking pressure (bar)

	Size 10	Size 16, Size 20	Size 25, Size 32
1	1.5	2.5	2.5
2	3	5	5
3	6	7.5	8
4	10	10	10

## Control pressure-load pressure-characteristic curve

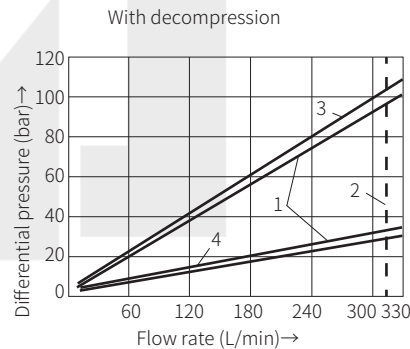
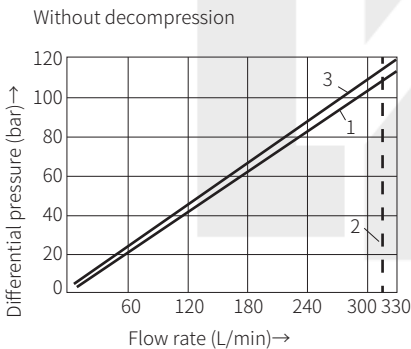

- 1 Scatter range
- 2 Limit value
- 3 Conical valve core
- 4 Decompression

## Component size

Size unit: mm

Subplate mounting SV/SL...4XJ/...

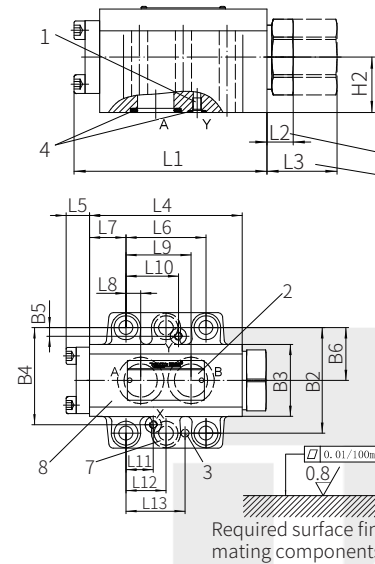

1. Port Y for valve model "SL" (the port is blocked for model "SV")
2. Name plate
3. Locating pin hole
4. O-ring  
-for ports A and B  
-for ports X and Y
5. Valve with cracking pressure "1" and "2" (dimension L2)
6. Valve with cracking pressure "3" and "4" (dimension L3)
7. 6 valve fixing holes for model SV/SL30

Required surface finishing of mating components

Valve fixing screw

- 10 size: 4-M10x50-10.9 grade GB/T70.1-2000  
Tightening torque  $M_A=60\text{Nm}$
- 20 size: 4-M10x70-10.9 grade GB/T70.1-2000  
Tightening torque  $M_A=60\text{Nm}$
- 30 size: 4-M10x85-10.9 grade GB/T70.1-2000  
Tightening torque  $M_A=60\text{Nm}$

It must be ordered separately if connection subplate is needed. Subplate model:

- 10 size: G460/01 (G3/8"); G460/02 (M18x1.5)  
G461/01 (G1/2"); G461/02 (M22x1.5)
- 20 size: G412/01 (G3/4"); G412/02 (M27x2)  
G413/01 (G1"); G413/02 (M33x2)
- 30 size: G414/01 (G1-1/4"); G414/02 (M42x2)  
G415/01 (G1-1/2"); G415/02 (M48x2)

Model	Size	L1	L2	L3	L4	L5	L6	L7	L8	L9	L10	L11
SV	10	101.7	14.3	14.3	89	31.4	42.9	24	7.2	35.8	-	21.5
	20	132.5	18.1	48.1	115	17.5	60.3	27.5	11.1	49	-	20.6
	32	155.5	35.6	45.6	134	21.5	84.2	39	16.7	67.5	-	24.6
SL	10	101.7	14.3	14.3	89	31.4	42.9	24	7.2	35.8	21.5	21.5
	20	132.5	18.1	48.1	115	17.5	60.3	27.5	11.1	49	39.5	20.6
	32	155.5	35.6	45.6	134	21.5	84.2	39	16.7	67.5	59.5	24.6

Model	Size	L12	L13	B1	B2	B3	B4	B5	H1	H2	H3	B6
SV	10	-	31.8	83	66.7	44	58.8	-	51	29	34	42.25
	20	-	44.5	99.5	79.4	62.5	73	-	71	38.4	56	39.7
	32	42.1	62.7	118	96.8	76	92.8	-	85	42.5	70	48.4
SL	10	-	31.8	83	66.7	44	58.8	7.9	51	29	34	42.25
	20	-	44.5	99.5	79.4	62.5	73	6.4	71	38.4	56	39.7
	32	42.1	62.7	118	96.8	76	92.8	3.8	85	42.5	70	48.4

Threaded connection SV/SL...4XJ/...

07

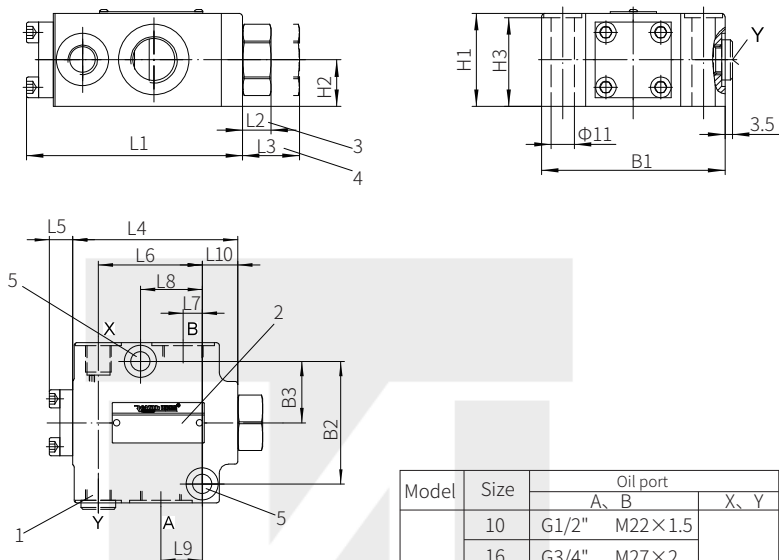

1. Port Y for valve model "SL"  
(the port is blocked for model "SV")
2. Name plate
3. Valve with cracking pressure "1" and "2"  
(dimension L2)
4. Valve with cracking pressure "3" and "4"  
(dimension L3)
5. 2 valve fixing holes

Model	Size	Oil port	
		A, B	X, Y
SV	10	G1/2" M22×1.5	G1/4" M14×1.5
	16	G3/4" M27×2	
	20	G1" M33×2	
	25	G1 1/4" M42×2	
	32	G1 1/2" M48×2	
SL	10	G1/2" M22×1.5	G1/4" M14×1.5
	16	G3/4" M27×2	
	20	G1" M33×2	
	25	G1 1/4" M42×2	
	32	G1 1/2" M48×2	

Model	Size	L1	L2	L3	L4	L5	L6	L7	L8	L9	L10	B1	B2	B3	H1	H2
SV	10	102.5	13.5	13.5	89.8	12.7	56.5	10.5	33.5	22.5	19.3	87	66.7	33.4	44	42
	16、20	132.5	18.1	48.1	115	17.5	74.5	17.2	50.5	36.2	27	106	79	40.5	69	67
	25、32	155.5	35.6	45.6	134	21.5	101.2	25.5	84	50.5	18	130	96.8	48.4	86	84
SL	10	102.5	13.5	13.5	89.8	12.7	56.5	10.5	33.5	22.5	19.3	87	66.7	33.4	44	42
	16、20	132.5	18.1	48.1	115	17.5	74.5	17.2	50.5	36.2	27	106	79	40.5	69	67
	25、32	155.5	35.6	45.6	134	21.5	101.2	25.5	84	50.5	18	130	96.8	48.4	86	84

